

VGC Gypsum Centrifuge Flue Gas Desulphurisation (FGD)



2 Excellence since decades

- 1917 Ferrum Ltd., engineering works and foundry, is founded as a family owned company in Rapperswil in Switzerland.
- 1935 For the first time Ferrum produces industrial centrifuges for the pharmaceutical and chemical industries.
- 1994 Ferrum takes over the centrifuge department of Sulzer-Escher Wyss with the complete range of pusher and scraper centrifuges, and also all the employees with their many years of experience. As a result of this take-over, Ferrum is able to significantly expand its product range and centrifuge know-how.
- Today** With more than 3500 pusher centrifuges delivered as well as more than 2700 scraper centrifuges, Ferrum is a world-leading centrifuge manufacturer.



Our factory at our headquarters in Switzerland

Your benefits: A strong partner with excellent prospects!

Ferrum Ltd. is a Swiss family business and is still in the possession of the founding family. The broad product range, the extensive know-how of the employees, the worldwide business, as well as a very high level of self-financing ensure a very strong market position with excellent prospects for the future.

Expertise all under one roof

Ferrum offers you customer-specific complete systems from a single source and, with its unique vertical integration, guarantees the highest quality without interface problems. We build our centrifuges and automation systems in-house; we also manufacture most of the mechanical components in our foundry and production department.

Always state-of-the-art

Ferrum centrifuge systems are state-of-the-art. In collaboration with our customers we continuously further the development of our designs and automation systems, and modify them to comply with the latest directives and standards.

Flue gas cleaning steps

In most plants flue gas cleaning comprises of three main steps:

- DeNOx: NOx gases are removed from the flue gas. Air and ammonia are added, water and nitrogen are generated
- Dust removal: dust in the flue gas is removed by an electro-filter
- Desulphurisation: sulphur dioxide is removed from the flue gas

Desulphurisation (FGD) methods

Depending on plant conditions (size, construction, emission regulations, waste removal, etc.) different flue gas desulphurisation methods can be used: dry process, semi-dry process, wet scrubbing process.

The most common method is wet scrubbing using limestone slurry as absorbent. Centrifuges are used only for wet scrubbing processes.

Flue gas desulphurisation system using wet scrubbing process

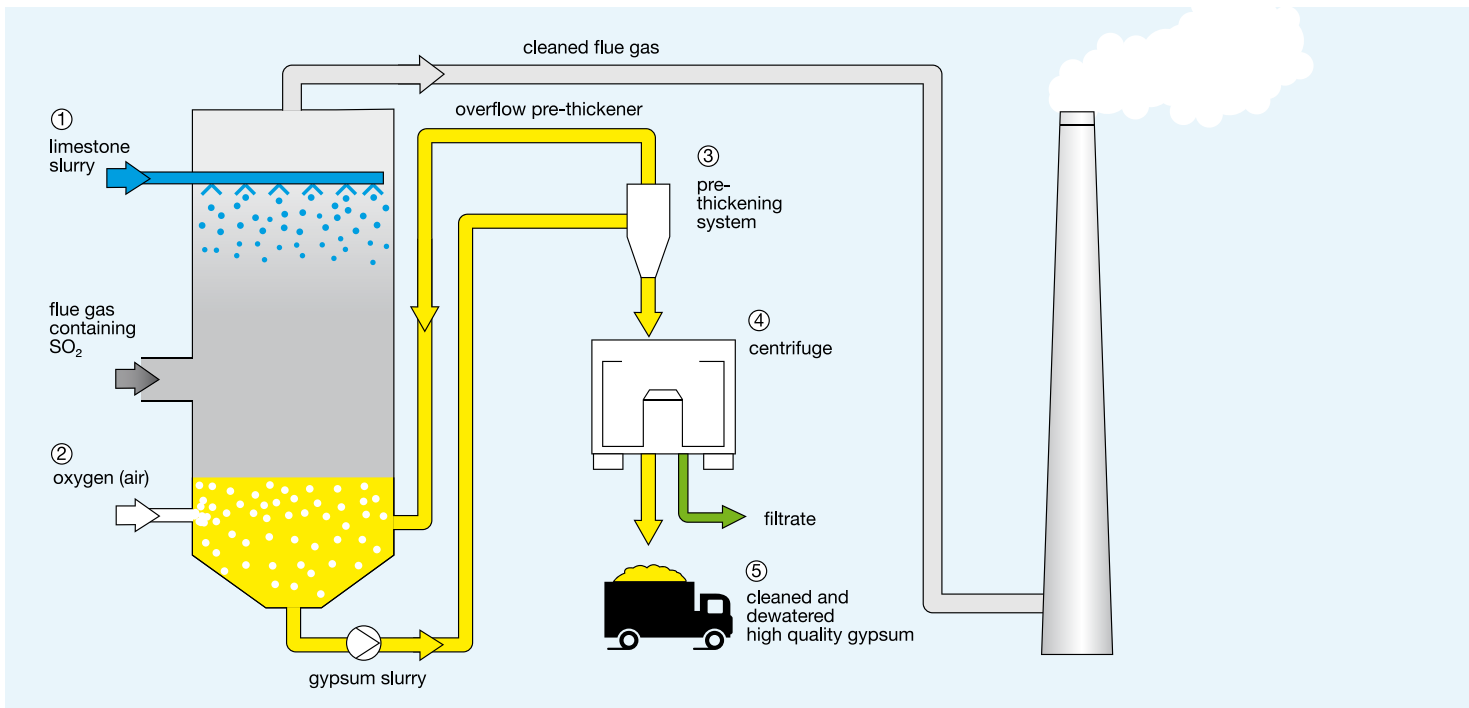

Typical wet scrubbing flue gas desulphurisation system

- ① Limestone slurry is sprayed into the flue gas and reacts with sulphur dioxide (SO_2). Calcium sulphite and carbon dioxide are generated.
- ② Calcium sulphite slurry is collected in the bottom part of the scrubber. Through air injection this slurry is enriched with oxygen and the calcium sulphite is oxidised to calcium sulphate dihydrate (gypsum).
- ③ Pre-thickening with hydro-cyclones and buffer system or equivalent.
- ④ In the centrifuge, impurities (mainly chlorides) are washed out and the gypsum slurry is dewatered.
- ⑤ The gypsum washed and dewatered in the centrifuge has a very high quality with low residual moisture (6-10 %-w/w) and low chlorides content (< 100 ppm). This gypsum can be used in the building materials industry for gypsum wall boards, etc.

4 Ferrum Gypsum Centrifuge

This centrifuge is specially designed for flue gas desulphurisation applications in coal fired power plants and waste incineration plants.

- Robust and reliable design
- Highest availability in permanent operation and even under extreme and irregular plant conditions
- Minimum power consumption
- Quiet and clean work environment
- Best separation performance
- High throughput
- High quality gypsum with maximum purity and minimal residual moisture

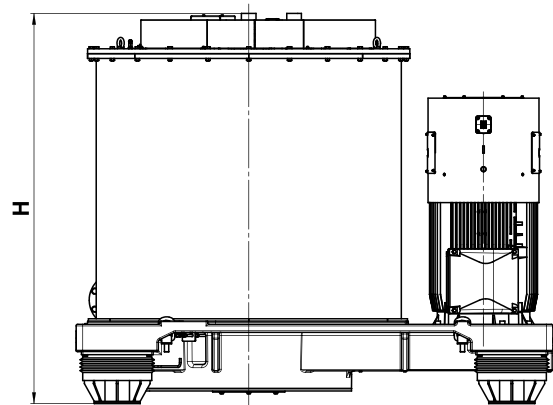
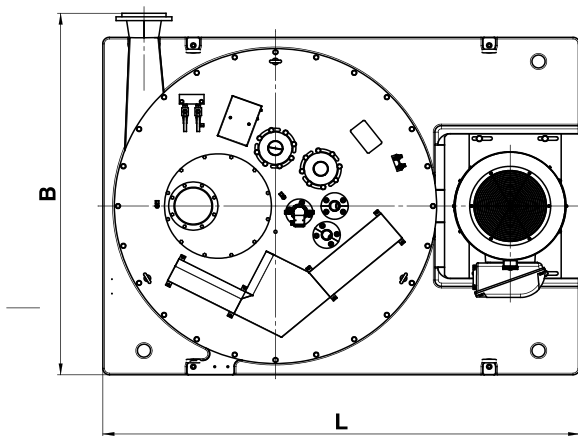

VGC	1250/800	1250/1000	1600/1000	1600/1250	Unit
Basket diameter	1'250	1'250	1'600	1'600	[mm]
Basket height	800	986	986	1'250	[mm]
Filter surface	3.14	3.87	4.96	6.28	[m]
Useful volume (100 %)	501	617	1'011	1 282	[dm]
Max. rotor speed	930	930	820	820	[min]
Max. G force	604	604	601	601	[g]
Centrifuge weight (without load)	6'500	6'700	10'400	10'900	[kg]
Dimensions (LxBxH)	2'500x1'850x1'800	2'500x1'850x2'000	2'900x2'250x2'200	2'900x2'250x2'450	[mm]

Centrifuge Input (flue gas gypsum slurry)					
Solids content	30 - 60	30 - 60	30 - 60	30 - 60	[%-w/w]
Particle size	30 - 100	30 - 100	30 - 100	30 - 100	[µm]

Centrifuge Output (dewatered flue gas gypsum)					
Solids throughput	up to 3.5	up to 4.5	up to 7	up to 8	[t/h]
Residual moisture	6 - 10	6 - 10	6 - 10	6 - 10	[%-w/w]
Chloride content	< 100	< 100	< 100	< 100	[Cl ⁻ ppm]

All data without obligation as dependent on process conditions

Solid-liquid separation in a gypsum centrifuge

The solid-liquid separation is effected discontinuously in a sequence of specific process steps:

Filling and intermediate centrifugation

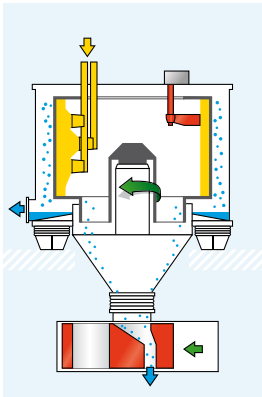

Washing

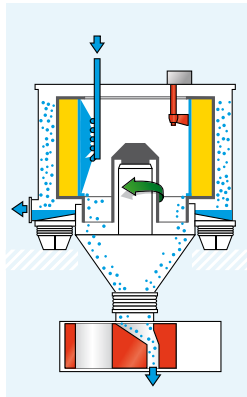

Centrifugation

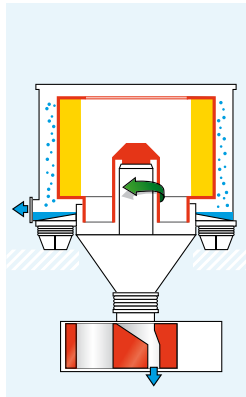

Scraping, solids discharge

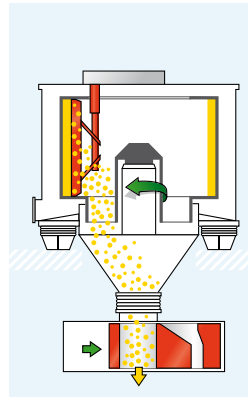

Residual heel removal

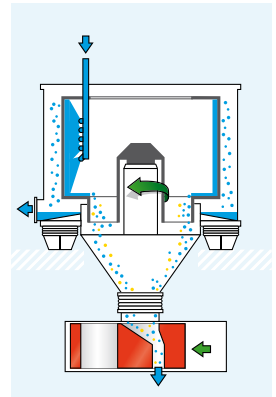

Filling

Before filling, the sorter mounted at the solids discharge cone is shifted to liquid discharge position. This prevents liquid reaching the next solids process step.

The gypsum suspension is applied evenly to the centrifuge basket via two feed pipes. The fill level control prevents overfilling of the basket.

Intermediate centrifugation

The basket is accelerated to partially dewater the cake.

Washing

After intermediate centrifugation, wash liquid is applied evenly to the product cake using the wash pipe. Impurities (mainly chlorides) are washed out.

Centrifugation

After washing, centrifugation takes place until the required residual moisture content in the filter cake is achieved.

Scraping, solids discharge

Before scraping, the product sorter is shifted to solids discharge position. At reduced speed the scraper knife swings into the filter cake and scrapes out the product vertically downwards.

Residual heel removal

To protect the filter cloth during scraping, a residual heel is left on the filter cloth. Before residual heel removal, the product sorter is shifted to liquid discharge position. The residual heel can be removed periodically depending on the product characteristics by using a separate wash pipe.

Automation of gypsum centrifuge systems

Ferrum in-house automation

The automation of centrifuges is of central importance to Ferrum.

Ferrum has invested many years into the development of centrifuge automation systems. Proven, standardised hardware and software modules are used as a basis and are supplemented with customer-specific elements.

All under one roof at Ferrum:

- Process automation and visualisation
- Engineering, software programming
- Panel shop: assembly of control and drive cabinets and operator panels
- Remote maintenance
- Documentation

Process automation and visualisation

The control and information display software permits easy operation and control of the solid-liquid separation process. Due to our extensive range of different control systems, operator panels and components from leading suppliers, we can efficiently implement comprehensive customer requirements.

State-of-the-art drive and safety systems

Our drive and safety control systems guarantee a safe and optimised operation of the centrifuge. The systems are state-of-the-art. They are continuously developed and adapted to our risk analyses as well as to the latest directives and standards. Frequency converters of the latest generation with integrated safety functions are used to control the speed.



Ferrum automation department: design and assembly of drive and control systems

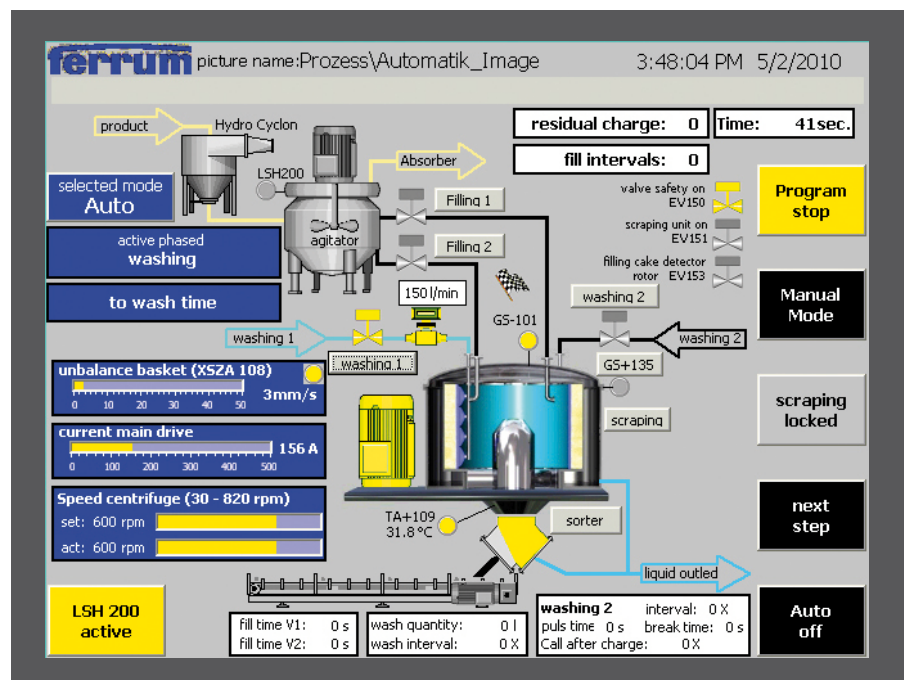

Operator panel display with process control and visualisation

Automation solutions for gypsum centrifuge applications

Ferrum offers various automation solutions for gypsum centrifuge applications, according to customer's requirements. Our automation systems ensure a safe and optimised solid-liquid separation process with high gypsum throughput.

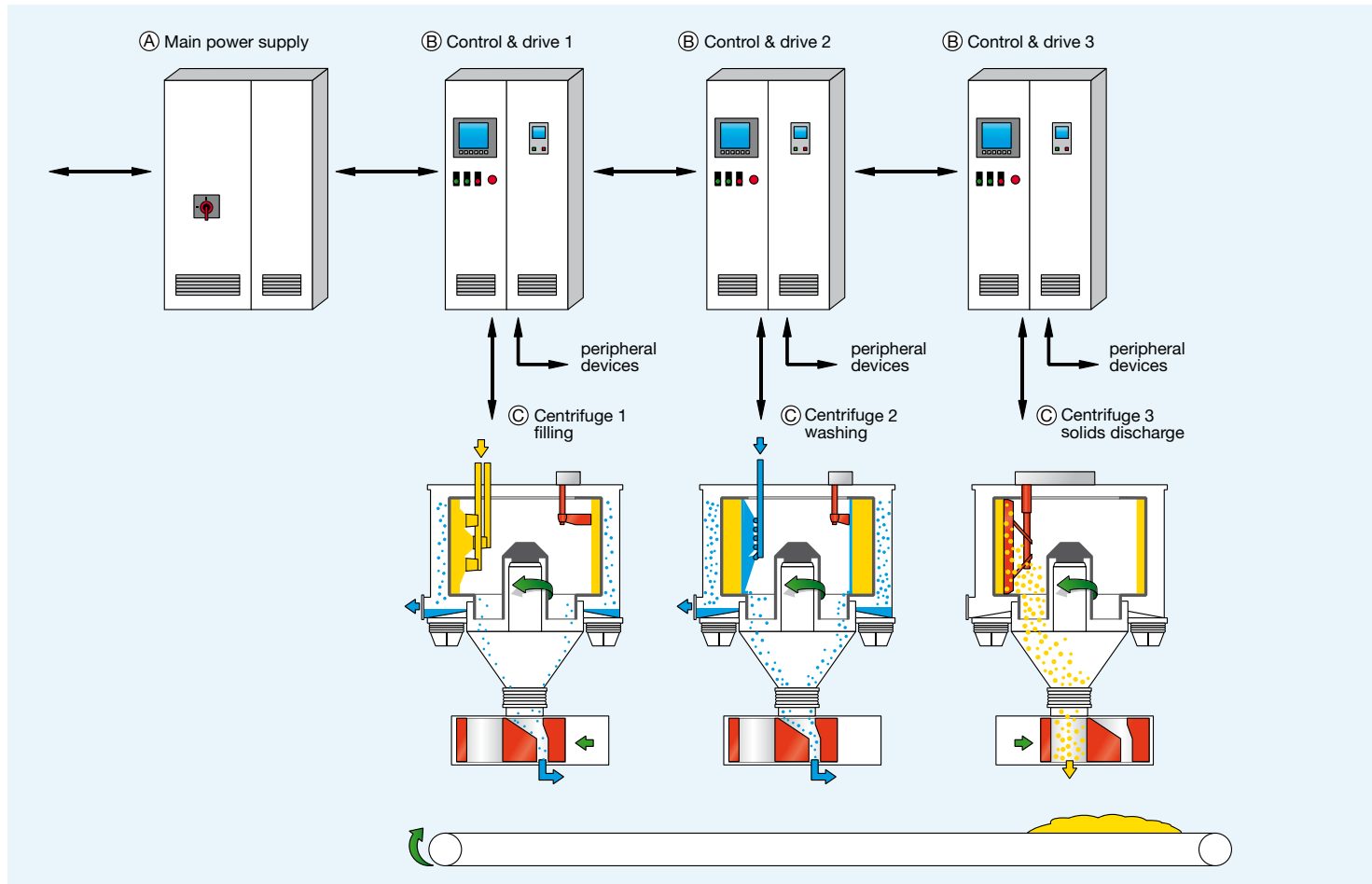

Possible automation system for a gypsum application with 3 or more centrifuges. To ensure smooth operation each centrifuge runs at a different process step.

A. Main power supply cabinet

In this cabinet the main power supply and the energy regeneration system are monitored. Further the main control and optionally a DCS interface are integrated.

B. Control and drive cabinets

Centrifuge control, operator panel and frequency converter are integrated. The cabinet is interfaced with the main power supply, the centrifuge and peripheral devices (valves, pumps, etc.).

C. Centrifuge with sensors

The centrifuge is equipped with various safety and position sensors. The sensor data is monitored by the control and drive cabinet of the corresponding centrifuge.

Centrifuge advantages over vacuum belt filters

Significant cost advantages

- Lower energy costs due to lower power consumption and energy regeneration
- Reduced wash liquid costs achieved by lower water consumption
- Lower building costs due to lower space requirements for the centrifuges (approx. ²/₃ lower than for a vacuum belt filter installation)
- Lower facility costs obtained by cleaner operation in a totally enclosed centrifuge system
- Reduced maintenance costs

Environmental protection

- Cleaner and quieter work environment achieved by a totally enclosed centrifuge system
- Gypsum can be used in the construction industry instead of being dumped in environmentally harmful landfill sites
- Today the focus on energy, water and maintenance costs as well as environmental protection has increased considerably. Ferrum gypsum centrifuges give advantages on all these aspects.

Better product quality

- High product purity due to efficient product wash capabilities
- Lower residual moisture achieved by more efficient liquid separation (6-10 %-w/w)



Ferrum gypsum centrifuge top view

Advantages	belt filter	centrifuge
Total costs	-	++
Product quality	-	++
Environmental protection	-	+

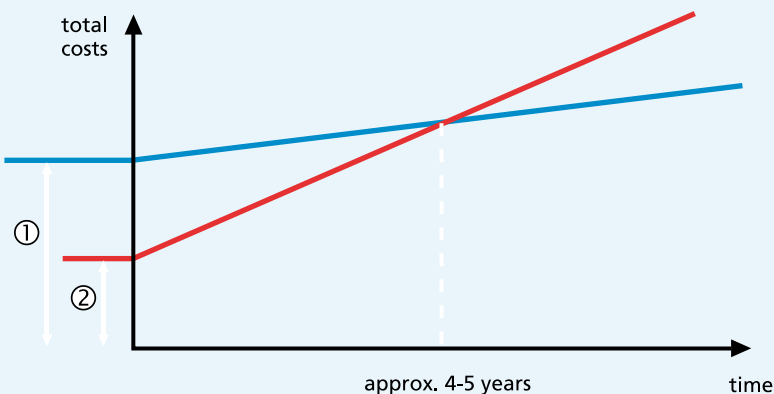

■ total costs centrifuge system

■ total costs vacuum belt filter system

① procurement costs centrifuge system

② procurement costs vacuum belt filter system

A centrifuge system generates higher procurement costs but lower running costs (maintenance, power consumption, etc.) over the vacuum belt filter system. Already after 4-5 years operation the centrifuge system generates lower total costs compared to the vacuum belt filter system.

Overview of our range of services

- Large stock of spare parts
- Prompt and uncomplicated support from our customer service team
- Worldwide service centres
- Maintenance, inspections, maintenance contracts based on BGR 500
- Various modifications, upgrades and integration of new drive and control systems
- Customer-specific training



Customer service and consultation

A large team of experienced service specialists as well as various service centres are available to our customers worldwide. In this way we can ensure fast and uncomplicated support.

Large stock of spare parts

We maintain a large stock of spare parts at our factory in Schafisheim. Our inventory and careful stock management ensure continuous availability and short delivery times.

Maintenance contracts based on BGR 500

For regular maintenance work we offer individual maintenance contracts with special conditions. We undertake all maintenance work at defined intervals and as a result guarantee the highest possible plant availability.

Customer-specific training

We will put together individual training courses for you, e.g. details on functioning of the centrifuge, its maintenance and operation as well as inspections, control and troubleshooting.



State-of-the-art stock management



Large stock of spare parts

It is our objective, in collaboration with you, to realise trouble-free solid-liquid separation with maximum performance, minimum energy consumption and consistent, reproducible product quality.



Ferrum gypsum centrifuge in operation

Configuration

Our process engineers configure the centrifuges and peripheral components to suit the specific application in accordance with your requirements. With more than 6200 centrifuges delivered worldwide, we can draw on extensive experience in the field of solid-liquid separation.

Product tests

Product tests are undertaken as required in our fully equipped laboratory or directly on your site. On request we will optimise your existing installations on-site and undertake pilot tests.

Project management and documentation

Efficient project management

From project start (kick-off) through acceptance test (FAT) in our factory to commissioning (SAT) on your site, our project managers guarantee a professional project management. Together we will run through the various approval as well as project phases based on an agreed schedule.

Clear documentation

With our centrifuges we supply detailed, customer-specific documentation fulfilling all directives and standards. This documentation includes documents to meet obligations as per customer specification (e.g. 3.1 certification), data sheets, operating manuals as well as a clear spare parts catalogue.





PM-230 pusher centrifuge
 Mechanical pusher drive
 Chemical applications



P-32 to P-120 pusher centrifuges
 Hydraulic pusher drive
 Chemical applications



VGC 1250 - 1600
 Vertical scraper centrifuges
 Flue gas desulphurisation gypsum



VBC 1000 - 1600
 Vertical scraper centrifuges
 Chemical, pharmaceutical applications



HPZ 630 - 1600
 Horizontal scraper centrifuges
 Pharmaceutical applications



HCZ 1000 - 2000
 Horizontal scraper centrifuges
 Chemical applications



VTC 630 - 1600
 Vertical top discharge centrifuges
 Chemical, pharmaceutical applications



VTC-M 320 - 500 mobile systems
 Vertical top discharge centrifuges
 Chemical, pharmaceutical applications



VTC-I 320 - 500 isolator centrifuges
 Vertical top discharge centrifuges
 Pharmaceutical, HAPI applications



Inertisation systems
 Ferrum InertoSafe® SIL 2
 Ferrum InertoSafe® ATEX



Automation – Customer-specific control and drive solutions, explosion protection up to Ex zone 1 (according to directive 94/9/EC)



Used equipment at good value
 Overhaul incl. function tests by Ferrum Ltd., short delivery times, 12 month guarantee



Subsidiaries

Ferrum Inc.
Houston, TX 77084 USA
Phone 877 WE FERRUM
877 93 337786
Fax 877 711 2FAX
877 711 2329
sales@ferrumus.com
www.ferrumus.com

Head office

Ferrum Ltd.
CH-5102 Rapperswil
Phone +41 62 889 14 11
Fax +41 62 889 15 13
zentrifugen@ferrum.ch
www.ferrum.ch

Ferrum India
Mumbai, 400016
Phone +91 22 243 14299
Fax +91 22 243 22276
ferrumindia@gmail.com